

# Dual NMEA 0183 Expander Model DX28 User Manual



The DX28 Expander is a 2-channel signal splitter/amplifier for NMEA 0183 data signals. It can be configured as one 1-in x 8-out expander, two 1-in x 4-out expanders, or an auto-switching expander. The two inputs are completely independent and can operate at the same or different baud rates up to 38,400. The selectable auto-switching feature enables automatic switchover to the **AUXILIARY** input when signal is lost from the **PRIMARY** input. A bicolor (green/red) status LED on each input shows data activity and a third LED (yellow) provides “overcurrent” fault indication. Each input drives four independent RS-422 outputs. The inputs use differential detectors, which are isolated from Power and Ground. The outputs are independent so that shorting one output does not affect the others.

The DX28 consists of two 4-way expanders. For a single 8-way expander, the 2 inputs are cross connected. To enable Auto-switching, connect the **Auto** terminal to **GND** so that all 8 outputs will pass the **PRIMARY** input and ignore the **AUXILIARY** input. A loss of **PRIMARY** data for 3 seconds automatically switches to the **AUXILIARY** input. When the **PRIMARY** signal returns, the DX28 immediately switches back to it.

The LED on each input flashes when data is received on that input, green for **PRIMARY** and red for **AUXILIARY**. In Auto-switching mode, both input LED’s flash the same color at the same time, indicating **PRIMARY** (green) or **AUXILIARY** (red) as active.

A third LED (yellow) is used for overcurrent indication. This LED turns on if the DX28 draws excess current. This can occur if an output terminal is misconnected. It may also indicate an internal fault of the DX28.

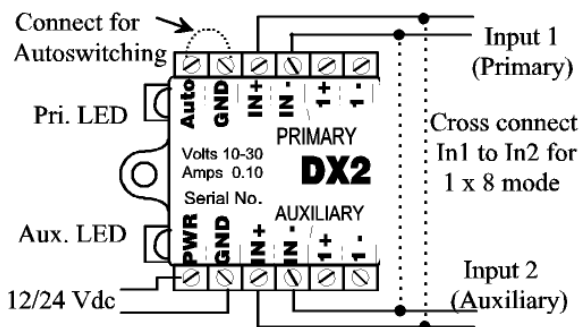

Connect the **PWR**, **GND**, and **IN** first. The **IN+/IN-** terminals connect to NMEA 0183 talkers (GPS, AIS, etc.). For those talkers that only have one “Data Out” wire, connect it to **IN-** and connect **IN-** to **GND**. If either **IN-** is not properly connected, unusual behavior may be observed such as faintly flashing LED(s). Verify proper operation of the status LED’s with NMEA data present.

If Auto-switching mode is desired, ground the **Auto** terminal. Note that both input LED’s will be green with **PRIMARY** data present or red if **PRIMARY** data is off for more than 3 sec. and **AUXILIARY** data is present.

The RS-422 outputs have voltage on both (+) and (-) lines. The **OUT-** lines should not be grounded as it causes driver circuit(s) to current limit. The figure shows two different ways the RS422 outputs connect to listeners. Only the **OUT+** terminal is used for single-ended (one-wire) listeners while both **OUT+** and **OUT-** terminals are used for differential (isolated) listeners.

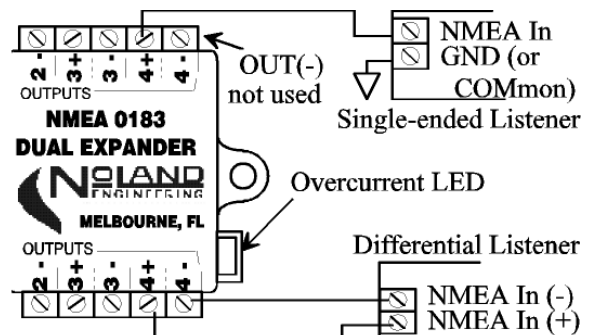

If the DX28 yellow LED comes on or flashes, it is probably because one of the RS-422 **OUT-** connections is grounded at the Listener. To find the error, disconnect each **OUT-** terminal one at a time until the yellow LED goes out. When the problem **OUT-** connection is found, leave it disconnected from that listener. If the yellow LED flashes or stays on with all outputs disconnected, an internal fault has occurred. In some cases the unit may still operate properly, but it may also need repair or replacement.

## SPECIFICATIONS

Input impedance	2K ohms
Input sensitivity	2V differential
Input baud rate	38,400 max.
Output level (RS-422)	3.5v → 500 ohms
Supply voltage	10 – 30 Vdc
No-load current	< 20 ma.
Full-load current	100 ma.
Overcurrent indication	> 100 ma.
Size (inches)	2.5 x 3.5 x 1.0
Weight (ounces)	3.0

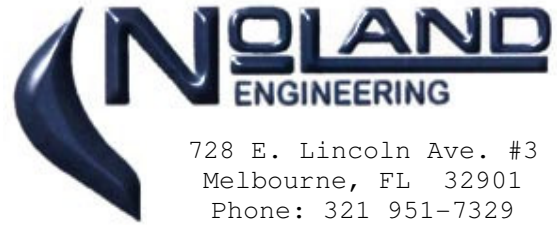

728 E. Lincoln Ave. #3  
Melbourne, FL 32901  
Phone: 321 951-7329  
FAX: 321 951-8773

<http://www.nolandengineering.com>  
email: [info@nolandengineering.com](mailto:info@nolandengineering.com)